

HUSSMANN®

SMBV

IMPACT

Impact Service Merchandiser With Straight Glass and Blower Coil for Meat and Deli - NSF Certified



Hussmann Impact Service Merchandiser With Straight Glass and Blower Coil for Meat and Deli Applications

HUSSMANN®
Impact

SMBV – Straight Glass Case With Blower Coil for Meat and Deli

Available in 4', 6', 8', and 12' lengths

Straight Glass With Large, Stainless Steel Top Display Surface

The SMBV offers a traditional straight glass design with a large, stainless steel display surface on top. This provides plenty of extra room for customer service and/or for displaying signs or related products such as spices, breads, etc.

Advanced Impact Design

The SMBV is a true "Impact" merchandiser, incorporating the best features and benefits of the Impact product line. These include advanced modular coils, superior energy efficiency, modular case design, durable bumper, and factory pre-adjusted expansion valves.

Reduced Refrigerant, Fewer Leaks

Patented Impact modular coils require 50% to 60% less refrigerant. Also, all return bend solder joints have been eliminated, which greatly reduces the possibility of refrigerant leaks.

Options

Options include third row canopy lights, mezzanine shelves, scale stands, thermometers and wrapping boards.

NSF Certified

The SMBV has been NSF certified to ANSI/NSF standard 7.

NOTE: These merchandisers are designed for use in stores when temperature and humidity do not exceed 75°F and 55% R.H.

NOTE: We reserve the right to change or revise specifications and product design in connection with any feature of our products. Such changes do not entitle the buyer to corresponding changes, improvements, additions, or replacements for equipment previously sold or shipped.

SMBV

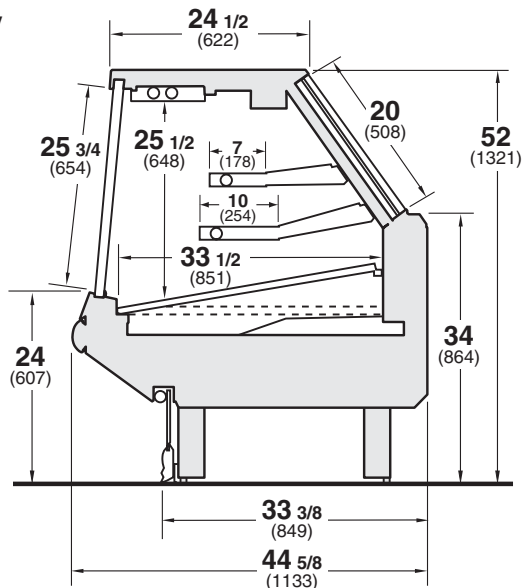

4', 6', 8', 12' Plan View

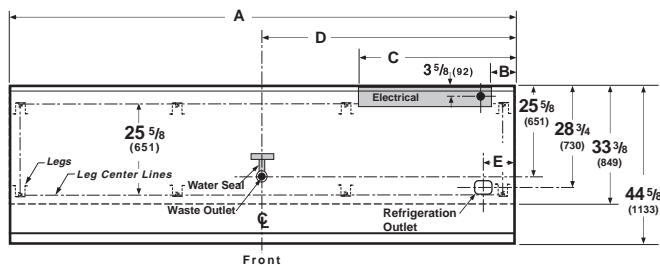

Dimension	A	B	C	D
4 foot	48 1/4 (1226)	7 (178)	41 3/8 (1051)	24 (610)
6 foot	72 1/4 (1835)	7 (178)	32 3/4 (831)	24 (610)
8 foot	96 3/8 (2448)	7 (178)	44 1/2 (1131)	24 (610)
12 foot	144 1/2 (3670)	7 (178)	44 1/2 (1131)	24 (610)

Note: Overall case length without ends or partitions

Note: Please use Hussmann's technical data sheets to get precise dimensions for all store layout purposes.

Web Site: www.hussmann.com
E-mail: hussmann-marketing@irco.com

IR Ingersoll Rand
Climate Control Technologies

Hussmann Corporation
12999 St. Charles Rock Rd.
Bridgeton, MO 63044-2483
(314) 291-2000
(314) 298-4756 Fax