

# HUSSMANN®

SSGV

## IMPACT

*Impact Service Merchandiser With Straight Glass and Gravity and Rear Coil for Seafood/Deli/Meat - NSF Certified*



# Husmann Impact Service Merchandiser With Straight Glass and Gravity and Rear Coil for Seafood/Deli/Meat

**HUSMANN®**  
**Impact**

## SSGV - Straight Glass Case With Gravity Coil and Rear Coil

Available in 4', 6', 8' and 12' lengths.

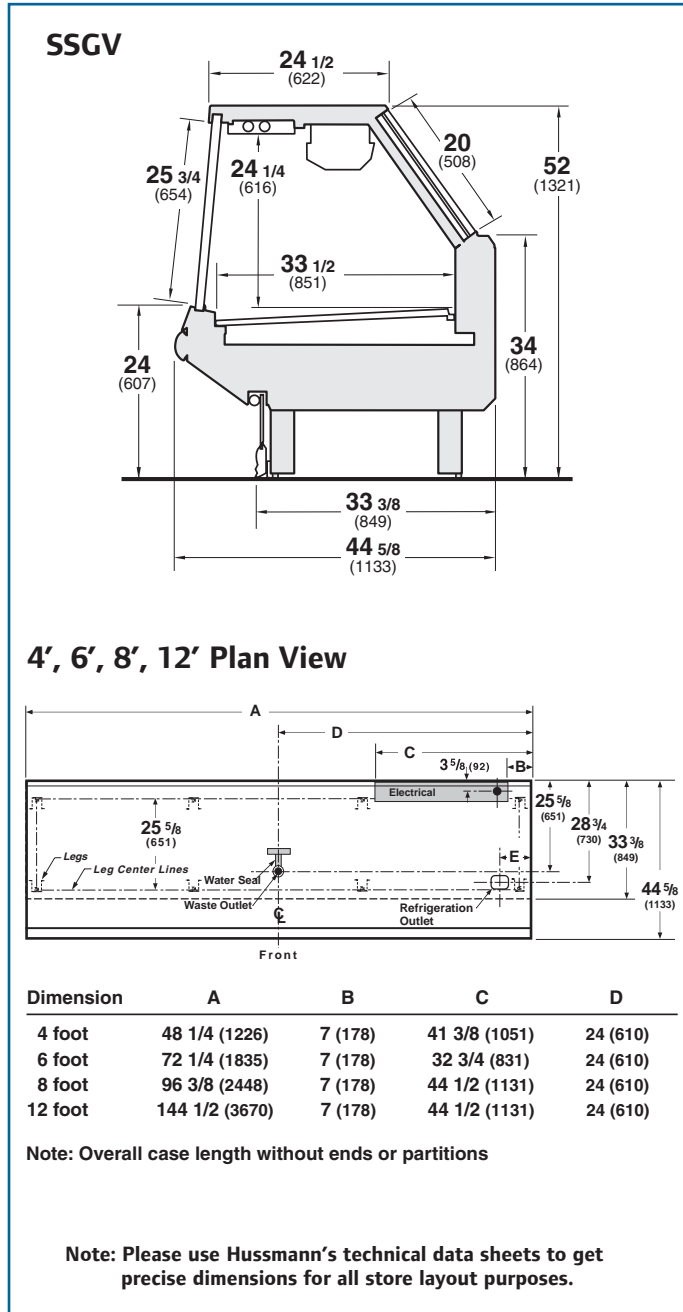

### Straight Glass With Large, Stainless Steel Top Display Surface

The SSGV offers a traditional straight glass design with large, stainless steel display surface on top. This provides plenty of extra room for customer service and/or for displaying signs or related products such as seafood sauces, spices, etc.

### Advanced Impact Design

The SSGV is a true "Impact" merchandiser, incorporating the best features and benefits of the Impact product line. These include advanced modular coils, superior energy efficiency, modular case design, durable bumper, and factory pre-adjusted expansion valves.

### Reduced Refrigerant, Fewer Leaks

Patented Impact modular coils require 50% to 60% less refrigerant. Also, all return bend solder joints have been eliminated, which greatly reduces the possibility of refrigerant leaks.

### Options

Options include third row canopy lights, stainless steel ice pans, scale stands, thermometers, mezzanine shelves and wrapping board. (Lighted mezzanine shelves not available on this model.)

### NSF Certified

The SSGV has been NSF certified to ANSI/NSF standard 7.

NOTE: These merchandisers are designed for use in stores when temperature and humidity do not exceed 75° F and 55% R.H.

NOTE: (We reserve the right to change or revise specifications and product design in connection with any feature of our products. Such changes do not entitle the buyer to corresponding changes, improvements, additions, or replacements for equipment previously sold or shipped.)

Web Site: [www.husmann.com](http://www.husmann.com)  
E-mail: [husmann-marketing@irco.com](mailto:husmann-marketing@irco.com)

**IR Ingersoll Rand**  
Climate Control Technologies

**Husmann Corporation**  
12999 St. Charles Rock Rd.  
Bridgeton, MO 63044-2483  
(314) 291-2000  
(314) 298-4756 Fax