

# HUSSMANN®

SSG

## IMPACT

*Impact Service Merchandiser With Curved Glass and Rear Coil  
for Seafood - NSF Certified*



# Hussmann Impact Service Merchandiser With Curved Glass and Gravity Coil for Seafood Applications

**HUSSMANN®**  
**Impact**

SSG - Single Pane Curved Glass Case With Gravity and Rear Coil for Seafood

Available in 4', 6', 8' and 12' lengths.

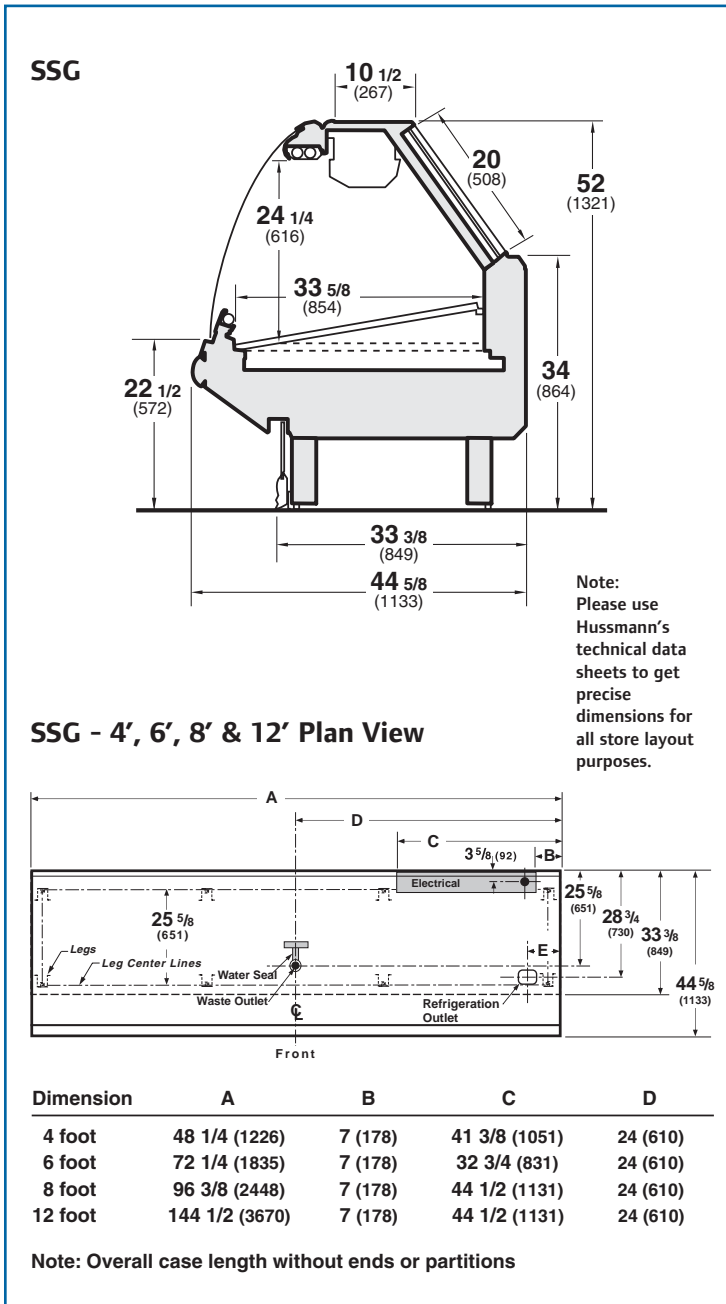

## Advanced Impact Design

The SSG and related SM and SS models are true "Impact" merchandisers, incorporating the best features and benefits of the Impact product line. These include advanced modular coils, superior energy efficiency, modular case design, durable bumper, factory pre-adjusted expansion valves, and seamless "bathtub" bottoms for quick, easy cleaning.

## Reduced Refrigerant, Fewer Leaks

Patented Impact modular coils require 50% to 60% less refrigerant. Also, all return bend solder joints have been eliminated, which greatly reduces the possibility of refrigerant leaks.

## Merchandising With Style

One look tells the story. Sleeker, cleaner exterior to enhance product display. Attractive molded end design. Excellent lighting and product visibility for "high impact" merchandising that sells. 30°, 45° and 90° inside and outside wedges available.

## Easy to Work

Front glass tilts up for easy stocking and cleaning. 10 1/2" stainless flat non-moveable top is standard. A large 20" rear door opening has an increased angle to improve reach and ergonomics. Options include scale stands, thermometers and wrapping boards. (Mezzanine shelves not available for seafood models).

## NSF Certified

The SSG has been NSF Certified to ANSI/NSF standard 7.

NOTE: These merchandisers are designed for use in stores when temperature and humidity do not exceed 75° F and 55% R.H.

NOTE: We reserve the right to change or revise specifications and product design in connection with any feature of our products. Such changes do not entitle the buyer to corresponding changes, improvements, additions, or replacements for equipment previously sold or shipped.

Web Site: [www.hussmann.com](http://www.hussmann.com)  
E-mail: [hussmann-marketing@irco.com](mailto:hussmann-marketing@irco.com)

**IR** Ingersoll Rand  
Climate Control Technologies

**Hussmann Corporation**  
12999 St. Charles Rock Rd.  
Bridgeton, MO 63044-2483  
(314) 291-2000  
(314) 298-4756 Fax