

# HUSSMANN®

D5X-ULEP, D6X-ULEP

## IMPACT EXCEL

*Ultra Low Front, High Capacity Dairy Merchandiser*



**Ultra Low Front Dairy Merchandiser**

**D5X-ULEP** Ultra Low Front Dairy, Traditional Height  
**D6X-ULEP** Ultra Low Front Dairy, Extended Height

Available in 4', 6', 8' & 12' lengths.

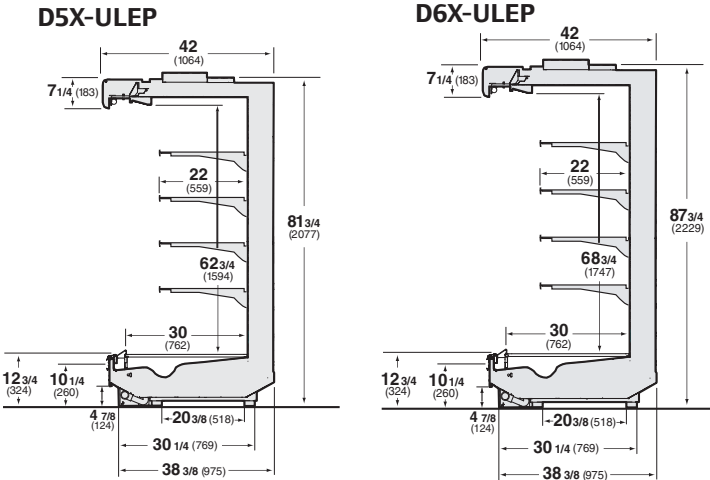

**Note:** Please use Hussmann's technical data sheets to get precise dimensions for all store layout purposes.

**D5X-ULEP, D6X-ULEP Plan View**

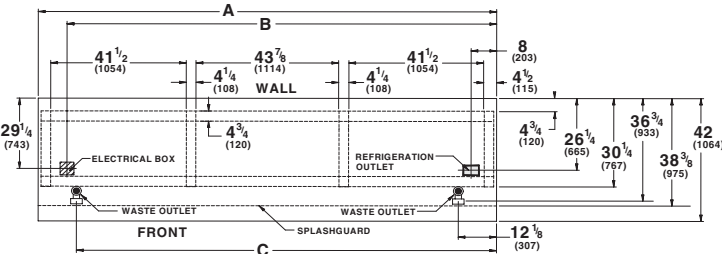

Dimension	A	B	C
4 foot	48 3/8 (1229)	36 1/4 (921)	36 1/4 (921)
6 foot	72 3/8 (1838)	60 1/4 (1530)	60 1/4 (1530)
8 foot	96 3/8 (2448)	84 1/4 (2140)	84 1/4 (2141)
12 foot	144 1/2 (3670)	132 3/8 (3363)	132 3/8 (3363)

**Note:** Case-to-case connections are made in the electrical box at the top of the case.

**Ultra Low Front for a Wall of Product**

The Ultra Low Front Dairy case helps you create a total "Wall of Product" in your dairy/deli departments. Front height has been lowered until it is virtually even with the bottom display racks. Shoppers have a full view of all product facings, top to bottom. Now you can maximize the merchandising opportunity without increasing footprint.

**Excel Styling Options**

The D5X-ULEP and D6X-ULEP are available with streamline, contour or lighted canopy options to let you create the look that works best for you. These styling options let you maximize your merchandising effectiveness.

**Superior Shelf Life**

With the Ultra Low Front Dairy, great refrigeration performance keeps food fresh. Modular coils with off-time defrost keep refrigerated temperatures extremely stable, reducing thermal shock.

**Superior Reliability**

Our 5 year modular coil warranty is the best available. Pre-set expansion valves are designed to hold optimal temperatures throughout the life of the case.

**Note:** These merchandisers are designed for use in stores when temperature and humidity do not exceed 75°F and 55% RH.

**Note:** We reserve the right to change or revise specifications and product design in connection with any feature of our products. Such changes do not entitle the buyer to corresponding changes, improvements, additions or replacements for equipment previously sold or shipped.

Web Site: [www.hussmann.com](http://www.hussmann.com)  
E-mail: [hussmann-marketing@irco.com](mailto:hussmann-marketing@irco.com)



**Hussmann Corporation**  
12999 St. Charles Rock Rd.  
Bridgeton, MO 63044-2483  
(314) 291-2000  
(314) 298-4756 Fax