

HUSSMANN®

PW

IMPACT

Produce Wide Island Display

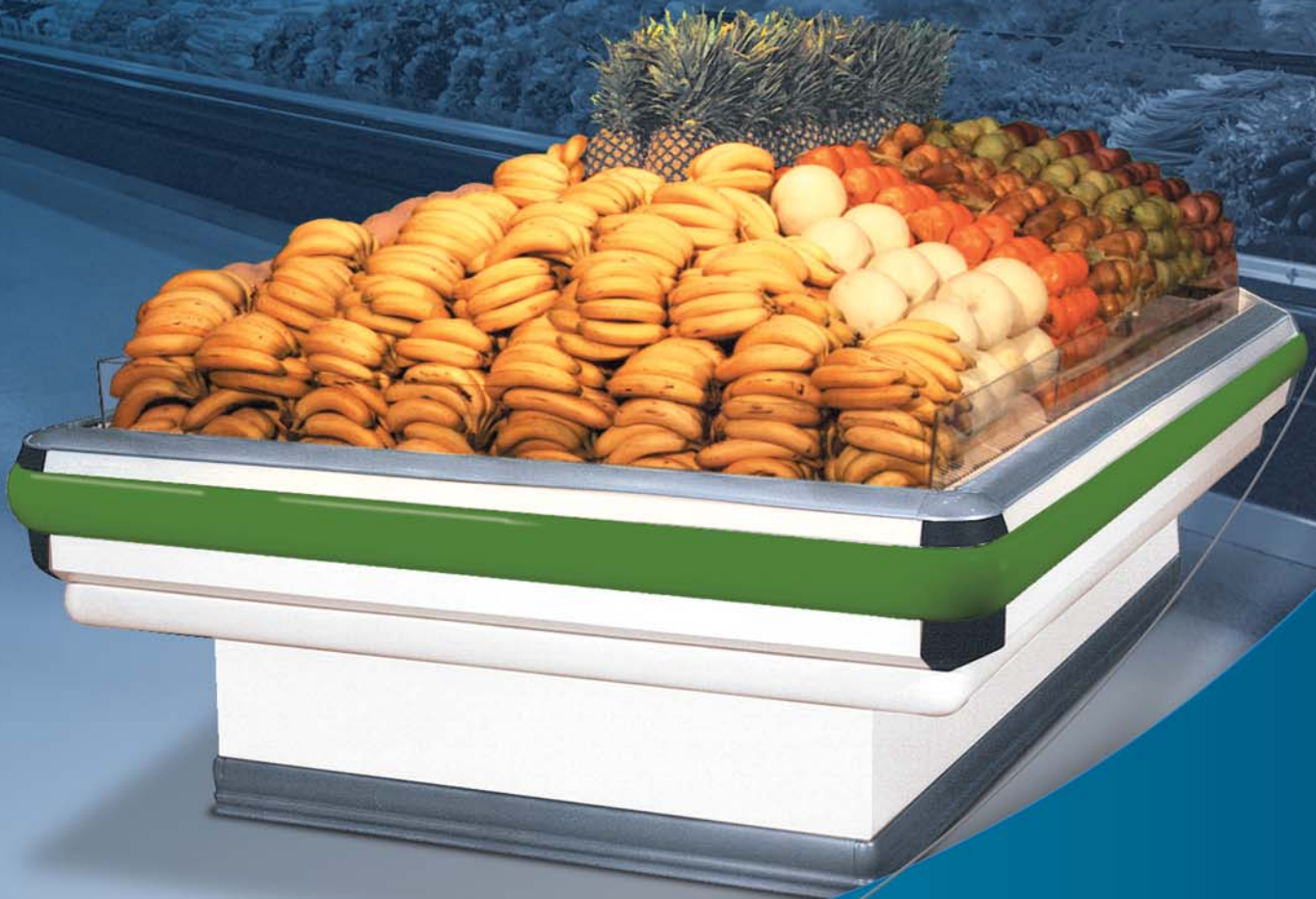

Produce Wide Island Display Cases

PW (6, 8, 12) - Refrigerated Produce Island

PW (6E, 8E, 12E) - Produce Island With High Efficiency Option

PWE - Refrigerated Produce Island End Case

PWEE - Refrigerated End Case With High Efficiency Option

Available in 4', 6', 8' and 12' Lengths.

5" Extended Center Flue Also Available.

HUSSMANN®
Impact

Excellent Refrigeration Performance

Designed for bulk produce applications, the PW provides dramatic advances in refrigeration performance for produce island displays. A unique coil, center flue and air discharge design forces cold air through products. Produce is kept colder with very stable and consistent temperatures throughout the entire display area. Each end case also has a dedicated coil and fan package to ensure superior refrigeration performance.

Less Refrigerant Needed

Impact modular coils require 50% to 60% less refrigerant within the coil than full length coils.

Permanently Adjusted Expansion Valves

All TXVs used with Impact modular coils are permanently adjusted at the factory. This produces two important benefits:

1. Faster installations
2. Valves that operate at peak performance settings throughout the life of the fixture

Quick, Easy Cleaning

High impact polystyrene bottoms with seamless, radiused corners are leak-proof, rust-proof and much easier to clean. Lift out back panels provide quick access to fan assembly.

Solid Durability

Heavy duty corner assemblies are designed to stand up to the punishment of daily abuse. True shock absorbing dual bumper system further protects case exterior. Heavy duty base and skids.

NOTE: These merchandisers are designed for use in stores when temperature and humidity do not exceed 75°F and 55% R.H.

NOTE: We reserve the right to change or revise specifications and product design in connection with any feature of our products. Such changes do not entitle the buyer to corresponding changes, improvements, additions, or replacements for equipment previously sold or shipped.

Web Site: www.hussmann.com

E-mail: hussmann-marketing@irco.com

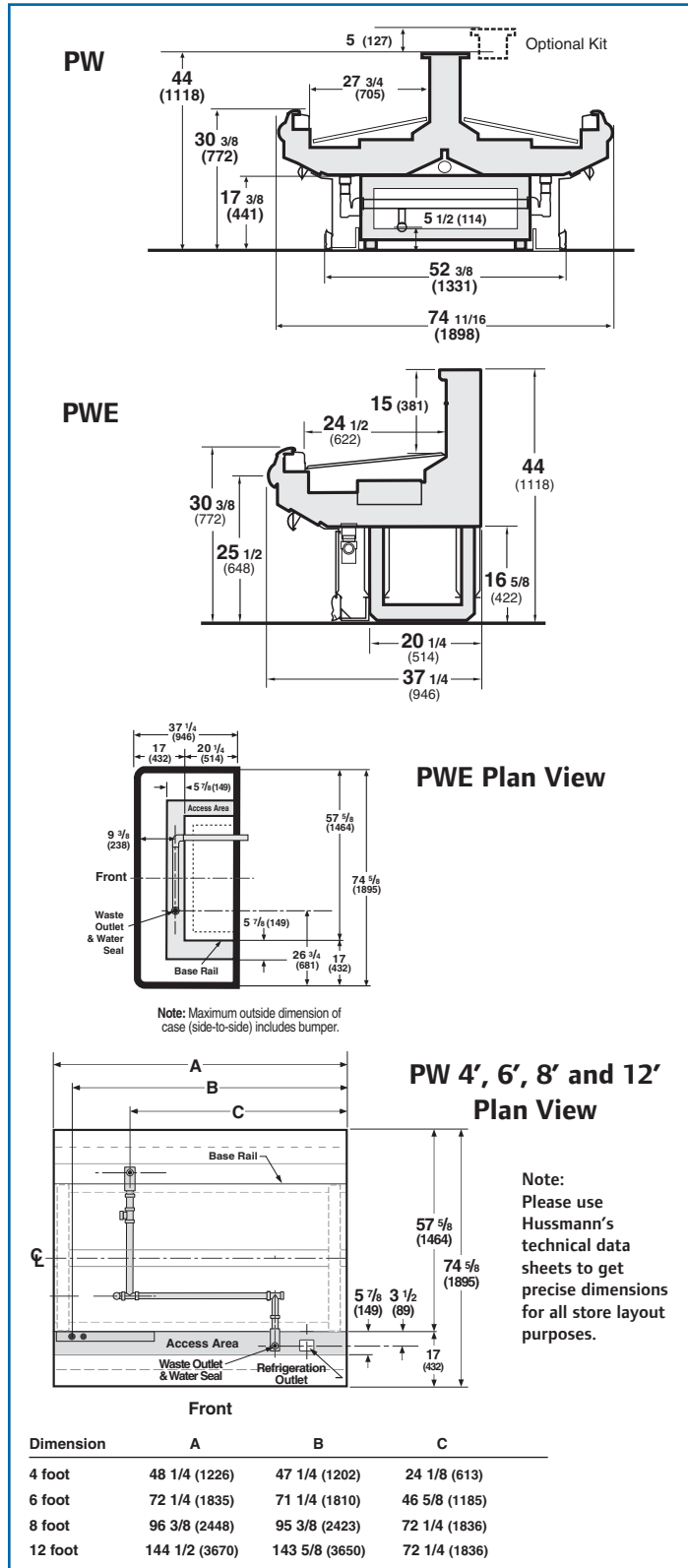

IR Ingersoll Rand
Climate Control Technologies

Hussmann Corporation
12999 St. Charles Rock Rd.
Bridgeton, MO 63044-2483
(314) 291-2000
(314) 298-4756 Fax