

HUSSMANN®

C2 LGE, M1GLE-93

IMPACT

*Convertible Medium Temp Island With Frozen
or Dual Temp End Caps*



Convertible Medium Temp Island With Frozen or Dual Temp End Caps



C2LGE - Convertible Multi-Decks Used Back to Back for Center of Island (Require 4" Elevated Bases)

M1GLE-93 - End Cap for Frozen or Dual Temp Applications

Flexible Island Merchandising

This unique island merchandiser provides loads of flexibility with convertible medium temperatures in the parent or center cases and low or dual temperatures in the end caps. The end caps are well suited for frozen meat or deli, but could be used for other products as well. An adjustable refrigeration thermostat for the end caps is optional.

The convertible center cases are designed for use with any medium temperature product, from fresh meat to bulk produce. So you have the ability to convert your merchandising plans as your needs change.

This island configuration has numerous possible applications. Merchandise fresh and frozen meats together as a perfect addition to your meat department. Or use as a Convenient Meal Assembly station, with fresh and frozen products together so your customers can get everything they need for a complete meal from one area. And with flexibility built in, you can change with the seasons or as new opportunities arise.

NOTE: These merchandisers are designed for use in stores when temperature and humidity do not exceed 75°F and 55% R.H.

NOTE: We reserve the right to change or revise specifications and product design in connection with any feature of our products. Such changes do not entitle the buyer to corresponding changes, improvements, additions, or replacements for equipment previously sold or shipped.

C2LGE With 4" Base Kit

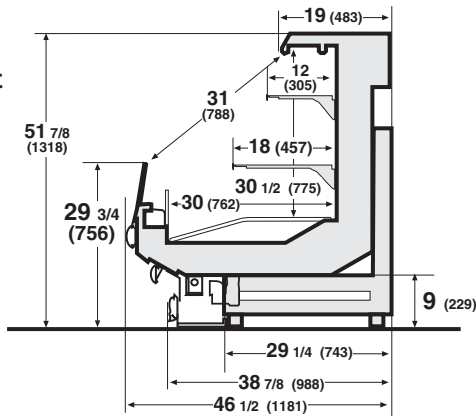

M1GLE-93

Note: Please use Hussmann's technical data sheets to get precise dimensions for all store layout purposes.

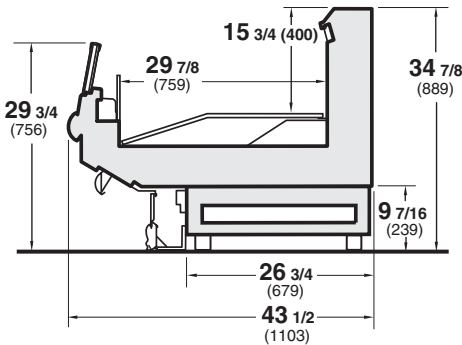

C2LGE, M1GLE-93 - 8' Plan View (With End Caps)

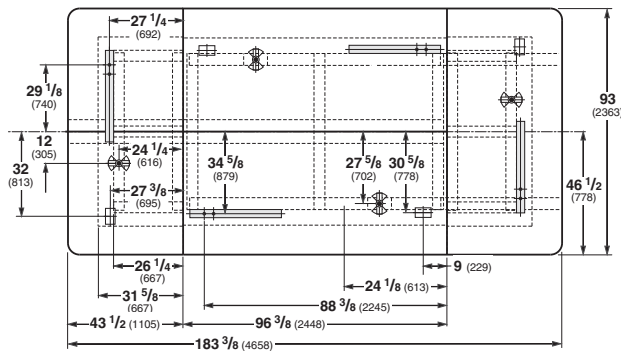

C2LGE, M1GLE-93 - 12' Plan View (With End Caps)

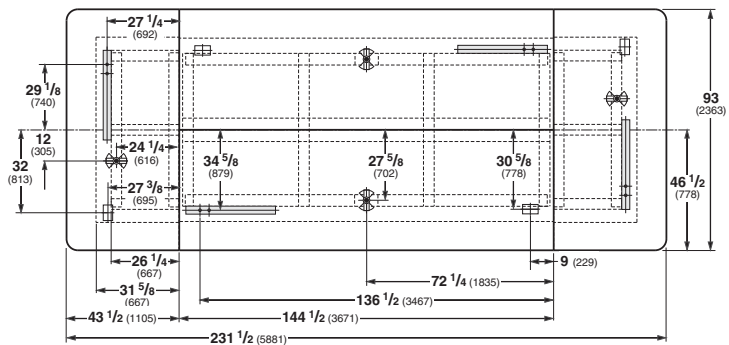

Web Site: www.hussmann.com
E-mail: hussmann-marketing@irco.com



Hussmann Corporation
12999 St. Charles Rock Rd.
Bridgeton, MO 63044-2483
(314) 291-2000
(314) 298-4756 Fax